



PERFORMANCE DATA SHEET

Meets or exceeds MEPS (Minimum Efficiency Performance Standards), as described by the US Department of Energy in docket 10CFR431 and Natural Resources Canada's Amendment 14

Catalogue #: MTR-124FDCH

HP	kW	Voltage	Frequency	EFF.	P.F.	Frame	Design	F.L. RPM
0,5	0,37	115 / 208 - 230	60Hz	74,6%	0,784	56C	B	1765

FLA			Service Factor	N.L. Amps @ 115V	N.L. Amps @ 230V	KVA Code	L.R. Amps @ 15v	L.R. Amps @ 230v
115	208	230		1,15	3,88		1,9395	M
5,70	3,15	2,85						

Start Cap.	Run Cap.	Main Winding Ω 115V @ 25°C	Main Winding Ω 230V @ 25°C	Auxillary Winding Ω @ 25°C	Safe Cold Start (Secs)
150 μ f/300vac	30 μ f/450vac	1,0100	4,050	4,410	12

Wgt. Lbs	PH	Duty	Insul. Class	Amb.	Elevation	Temp. Rise° C
27	1	Cont.	F	40°C	1000M (3,300 Ft)	46

% Efficiency		Power Factor		Torque		Protection
Full Load:	74,6%	Full Load:	0,78	Full Load Ft/Lbs	1,5	
3/4 Load:	69,1%	3/4 Load:	0,64	Locked Rotor %	358	
1/2 Load:	51,1%	1/2 Load:	0,52	Break Down %	331	

Rotor Inertia Wk2 Lb-Ft2	Max Load Inertia Wk2 Lb-Ft2	Shaft Material	Frame Material	DE Bracket Type	ODE Bracket Type	Enclosure	NEMA Rating	Lead Wire Size
/	/	Steel	Rolled Steel	Aluminium Alloy		TEFC	IP55	/

Ball Bearings		Grease	Mount Type	Orientation	Paint	Sound Pressure @ 3FT	Sound Power
DE	ODE						
6205	6203	Sealed Bearings	Rigid	Horizontal	Black	65	/

WIRING CONNECTION DIAGRAM : A

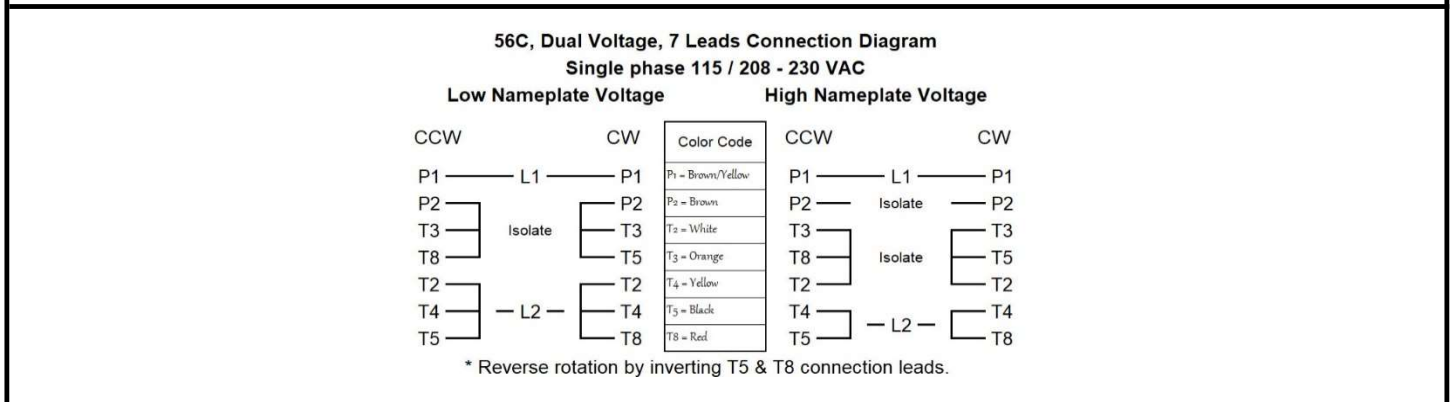



Date: 2023-12-22
 Customer: _____
 Contact: _____
 Submittee: J.C. Lavallée

Catalogue #: **MTR-124FDCH**

Meets or exceeds MEPS (Minimum Efficiency Performance Standards), as described by the US Department of Energy in docket 10CFR431 and Natural Resources Canada's Amendment 14

HP	VAC	RPM	Enclosure	Frame	Frequency	Design	Poles	LR Code Letter	Insulation Class	Temp. Rise °C
0,5	230	1765	TEFC	56C	60	B	4	M	F	46

Load %	0%	25%	50%	75%	100%	125%	150%
Amps	2,02	2,17	2,31	2,51	2,85	3,56	4,28
Torq ft/lbs	0	0,37	0,74	1,11	1,49	1,87	2,25
RPM	0	1791,25	1782,5	1773,75	1765	1756,25	1747,5
Eff	0	37,44	67,80	75,44	74,60	71,16	69,12
PF	0,00	50,00	51,74	64,29	78,40	79,97	82,32

	Locked Rotor	Pull-Up	Breakdown	Rated Load	Idle	Duty	S. F.	Ambient	Elevation	dBa @ 1M
Speed (RPM)	0	900	1440	1765	1800	Continuous	1,15	40°C	3,300 ft	65
Current (Amps)	21	17,9	12,5	2,85	2,0235	VFD Rating: Meets MG1 parts 31.4.4.2				
Torque (ft-lbs)	5,33	4,53	4,92	1,49	0,0	C.T.	4,05	V.T.	4,41	

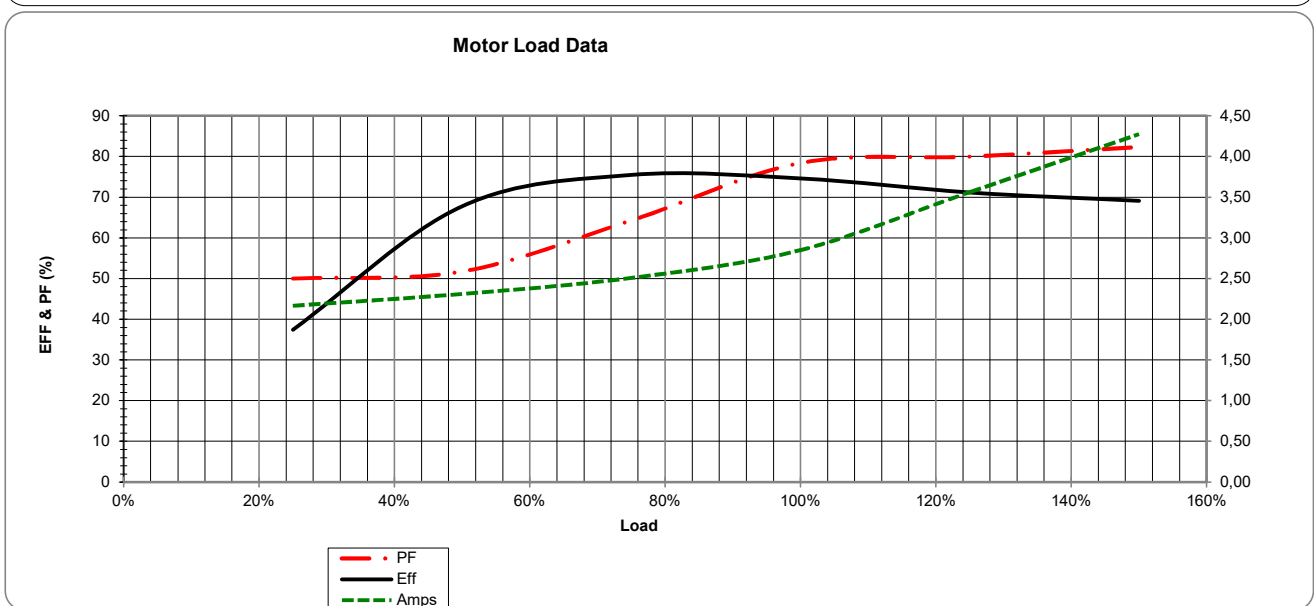
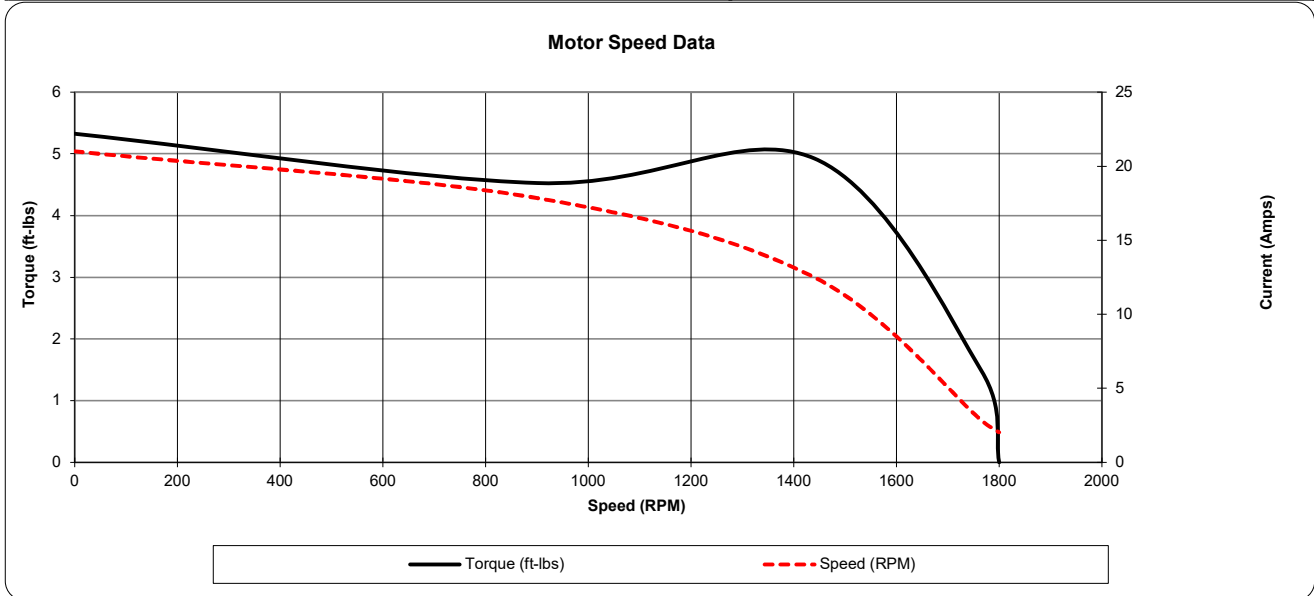

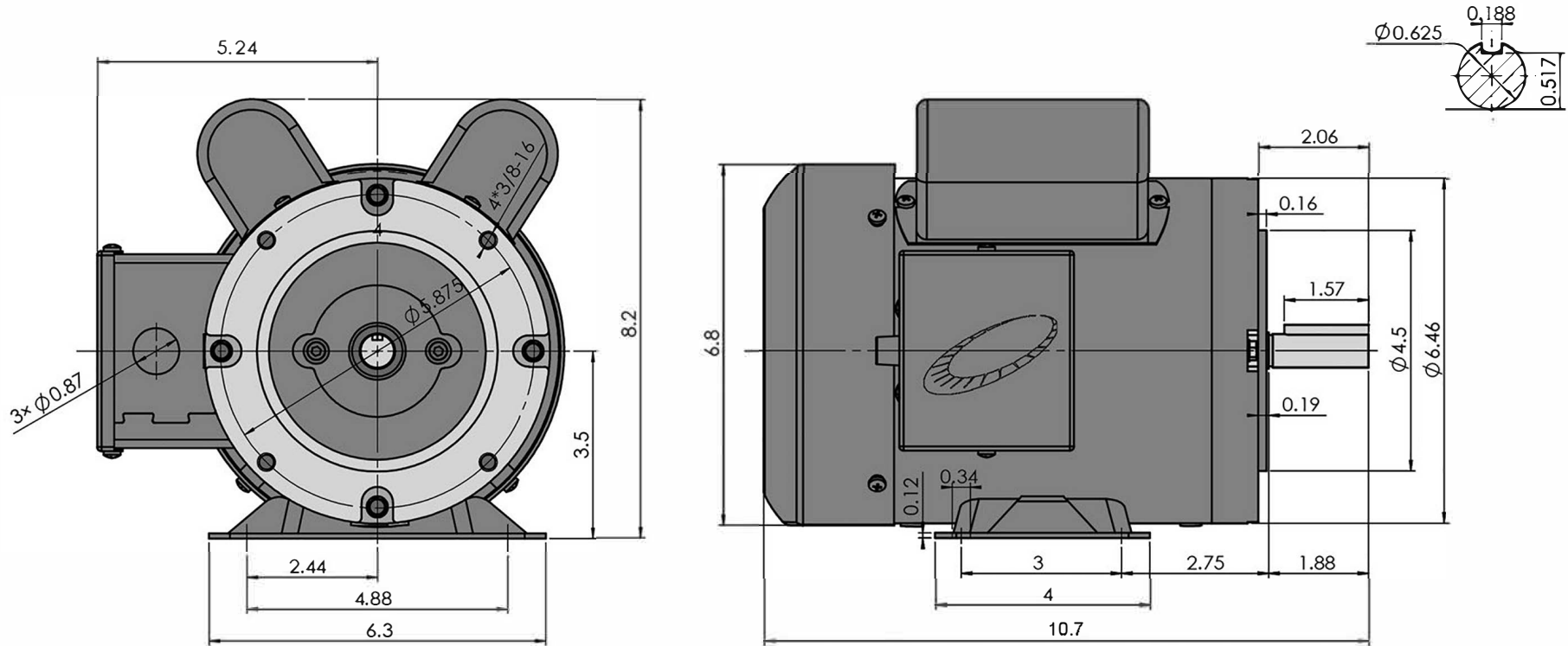

Version: 2HUA	Revised: July 2020	HP	RPM	FRAME	ENCLOSURE
Customer is responsible in determining that MaxMotion product will fit/perform suitably in the intended application		1/2	1800	56C	TEFC

MTR-124FDCH

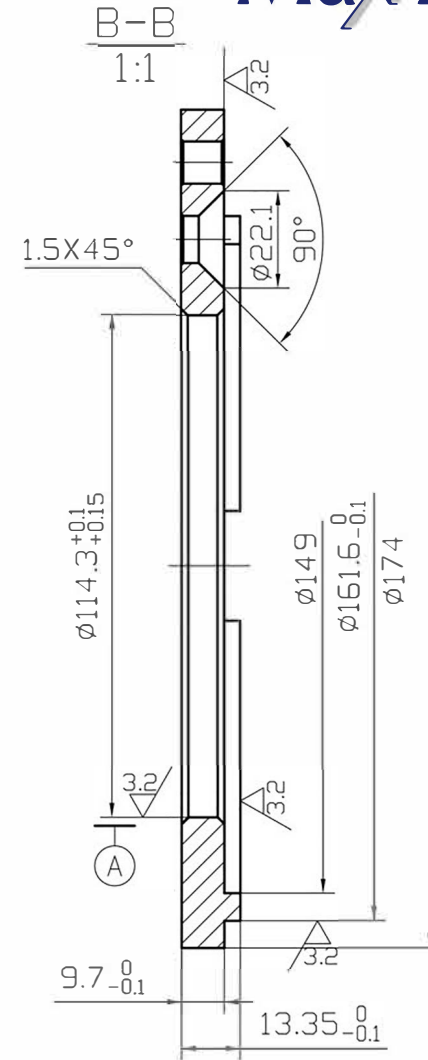
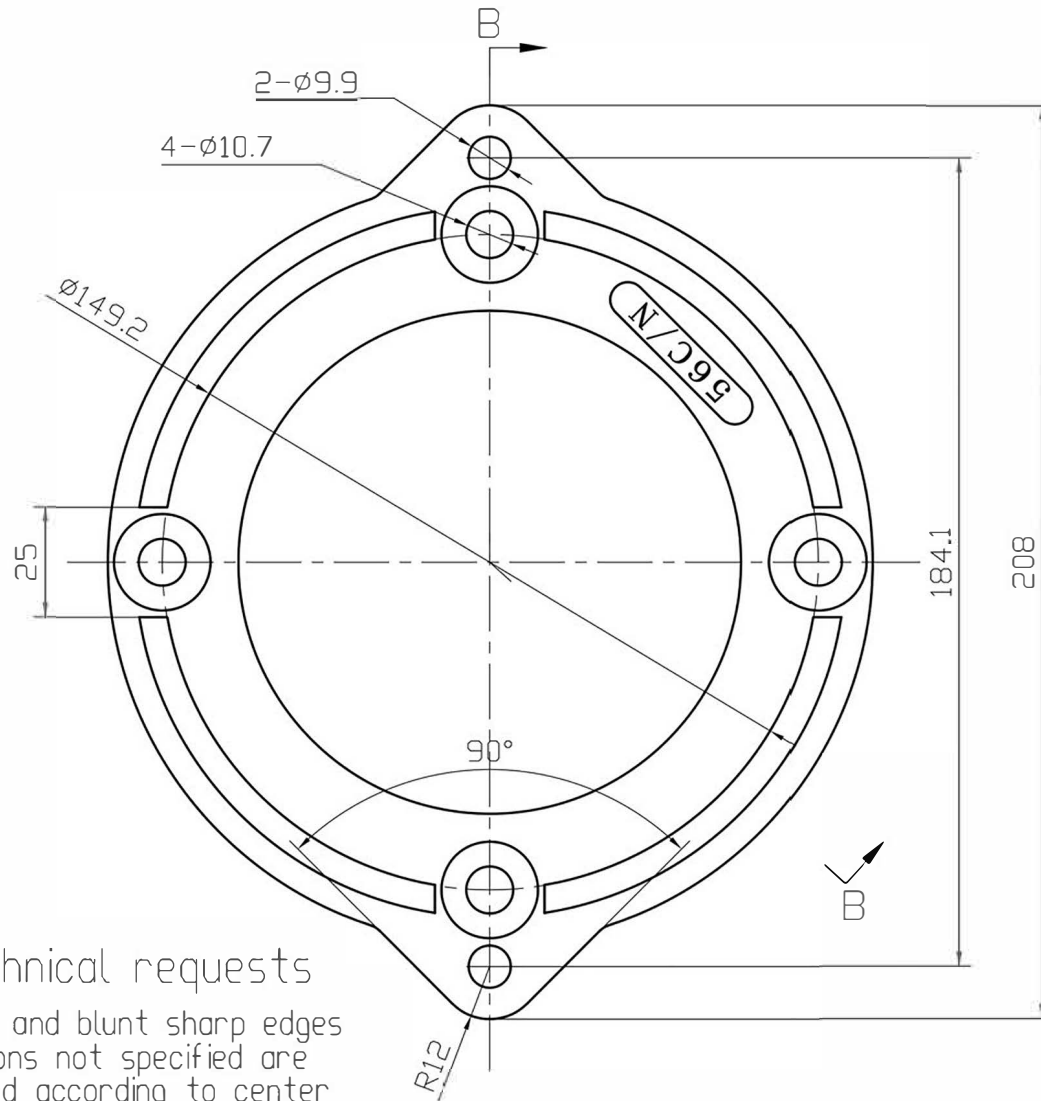

technical requests
 deburr and blunt sharp edges
 dimensions not specified are
 machined according to center
 symmetry

ITEM #: 56C/N

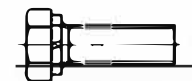

5/16-18UNCx1-1/4
 With Spring Washer Galvanized
 2 PCS

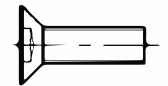

3/8-16UNCx1
 Blackening
 4 PCS

SINGLE PHASE GENERAL PURPOSE AC MOTORS

HEAVY GAUGE ROLLED STEEL CONSTRUCTION

TEFC TOTALLY ENCLOSED FAN COOLED

MaxMotion

Applications:

A versatile design allowing replacement of C-Face or rigid base TEFC motors, for use on gear reducers, pumps, fans, blowers, conveyors, and all agricultural equipment requiring a motor to meet demanding high starting torque applications in severe environmental conditions.

Features:

Design - L, suitable for ambient temperature of 40°C, altitude 1000M

Agency Listings and Standard - NEMA, CSAus and CSA Certified, RoHS Compliant

Service Factor - 1.15

Electrical Supply - 115/208-230VAC, 60Hz

Mounting - Universal mounting by feet or C flange.

Windings - VPI with additional dip and bake, with numbered and color coded wire leads.

Insulation - Class F insulation with B temperature rise.

Protection - Manually resettable thermal overload.

Voltage and Frequency Variation - $\pm 10\%$

Bearings - Permanently Lubricated High quality Double Shielded Ball Bearings with oversized DE bearings. Lithium based grease operating temperature range – 25° trough 175°C.

Earthing Terminals - Grounding screw in conduit box

Enclosure Protection - IP55

Frame Construction - Rolled Steel with cast aluminum end shields

Conduit Box - Rotatable 180°, with ½ NPT knockouts positioned for wiring access every 90° with rubber gasket between box and motor frame.

Nameplate - Stainless Steel with etched details.

Drain Hole - Positioned in the stator frame at the lowest point, when motors a horizontally mounted.

Fan Cover - Plastic fan & heavy duty plastic fan guard

Warranty - 1 year

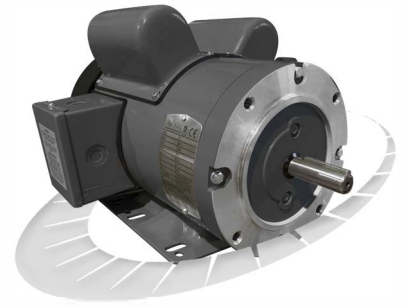

SINGLE PHASE GENERAL PURPOSE AC MOTORS

HEAVY GAUGE ROLLED STEEL CONSTRUCTION

TEFC TOTALLY ENCLOSED FAN COOLED



HP	FL RPM	VOLTS	FRAME	CATNO.	CONSTRUCTION	NOM EFF.	F.L. AMPS	CODE	WT (Lbs)	DE BRG	ODE BRG	LRT	"C" Dimension (Inch)
0.33	3520	115/208-230	56C	MTR-132FDCH	Rolled Steel	67.3	3.83/2.12-1.92	L	22	6205	6203	300% +	10.7
	1770	115/208-230	56C	MTR-134FDCH	Rolled Steel	68.8	3.92/2.17-1.96	M	26	6205	6203	300% +	10.7
0.50	3520	115/208-230	56C	MTR-122FDCH	Rolled Steel	71.3	5.03/2.78-2.52	L	25	6205	6203	300% +	10.7
	1765	115/208-230	56C	MTR-124FDCH	Rolled Steel	74.6	5.7/3.15-2.85	M	27	6205	6203	300% +	10.7
0.75	3520	115/208-230	56C	MTR-342FDCH	Rolled Steel	77.5	6.82/3.77-3.41	L	26	6203	6203	300% +	10.7
	1760	115/208-230	56C	MTR-344FDCH	Rolled Steel	77	7.33/4.05-3.66	L	31	6205	6203	300% +	11.5
1	3520	115/208-230	56C	MTR-102FDCH	Rolled Steel	77.9	8.61/4.76-4.31	J	30	6205	6203	300% +	11.5
	1760	115/208-230	56C	MTR-104FDCH	Rolled Steel	79.8	9.09/5.02-4.54	K	38	6205	6203	300% +	11.5
1.5	3520	115/208-230	56C	MTR-152FDCH	Rolled Steel	82.3	12.47/6.89-6.23	J	36	6205	6203	283%	11.5
	1750	115/208-230	56HC	MTR-154FDCH	Rolled Steel	81.8	12.41/6.86-6.2	J	44	6205	6203	294%	12.5
2	3510	115/208-230	56HC	MTR-202FDCH	Rolled Steel	83	15.92/8.8-7.96	H	42	6205	6203	273%	12.5
	1750	115/208-230	56HC	MTR-204FDCH	Rolled Steel	84.7	16.17/8.94-8.08	H	50	6205	6203	269%	13.66
	1750	115/208-230	145TC	MTR-204FDTH	Rolled Steel	84.7	16.17/8.94-8.08	H	51	6205	6203	269%	13.7
	1750	115/208-230	145TC	MTR-204FDTCH	Rolled Steel	84.7	16.17/8.94-8.08	H	51	6205	6203	269%	13.8
3	1770	208-230	184TC	MTR-304FDCH	Rolled Steel	87.4	13.2-11.3	H	96	6206	6205	230%	16.5
5	1760	208-230	184TC	MTR-504FDCH	Rolled Steel	85.9	23-19.30	G	109	6206	6205	230%	16.9
7.5	1770	208-230	215T	MTR-754FDH	Rolled Steel	88	33-28.10	H	154	6206	6205	321%	19
10	1770	208-230	215T	MTR-1004FDH	Rolled Steel	88	45.1-38.20	G	172	6206	6205	300%	19

